

Managing Interpersonal Relationships (Social Skills)

(Discussion Note)

2019



All interpersonal activities are more
or less directed by the
behaviors and attitudes
of an individual.



All human behaviour and attitudes are the **expression of deeper psychological orientation** that we have about ourselves and the others.



It is therefore necessary for us to analyze our orientations to establish better interpersonal relationships.

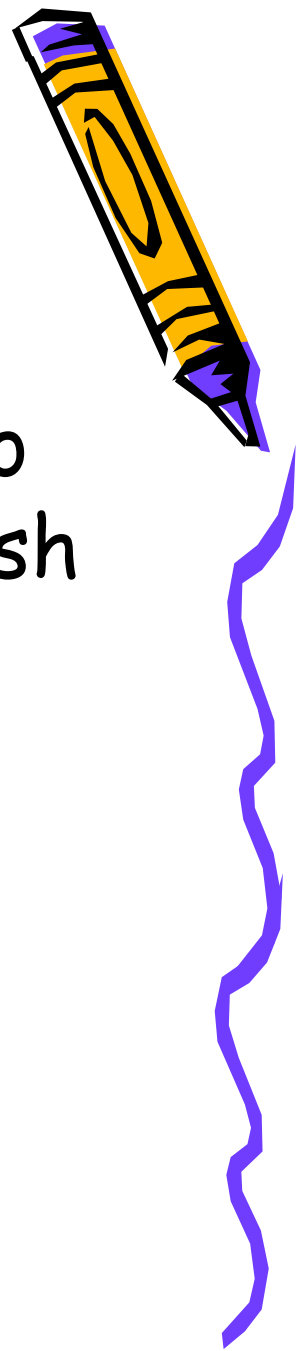

Transactional Analysis (TA)
developed by an *American*
psychologist/psychotherapist Dr.
Eric Berne can be used for this
purpose.

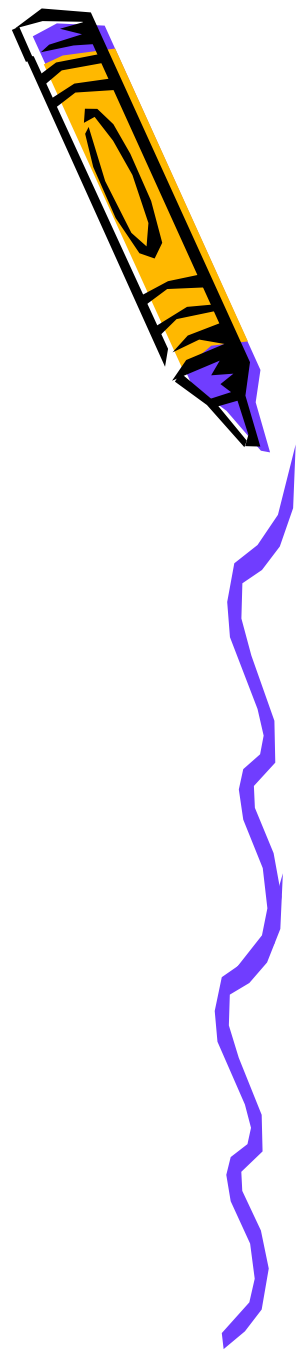

TA is a system for improving communication and for understanding human behavior through studying verbal and non-verbal message between the individuals.



The essence of TA is that, our behavior toward others can originate in any of three basic ego-states i.e. Parent (P), Adult (A), and Child (C).



Parent (P)

The Parent (P) is that part of us that reflects "*life as it is taught*". Thus, Parent derives from the model/s given us by our parents or substitute parents.



Our Parent is a mixture of the rules and norms which were passed to us started in the early stage of development. It may result in behavior which is punitive, judgmental, and critical or in behavior which is caring, protecting and nurturing.

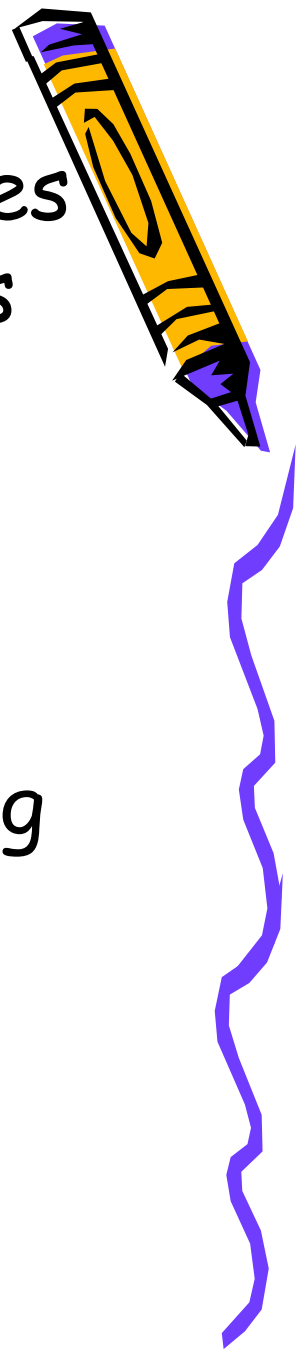

For example: don't do that, do as you are told, you're a clever boy, because I said so, who do you think you are, well done, you should know better, wait till your father gets home, put your face straight, don't let the family down, big boys don't cry, don't raise your voice to me, I love you, never go out looking untidy, etc.



Thus, within the parents there are two functional ego states i.e., The Nurturing Parent (NP) and Critical Parent (CP).

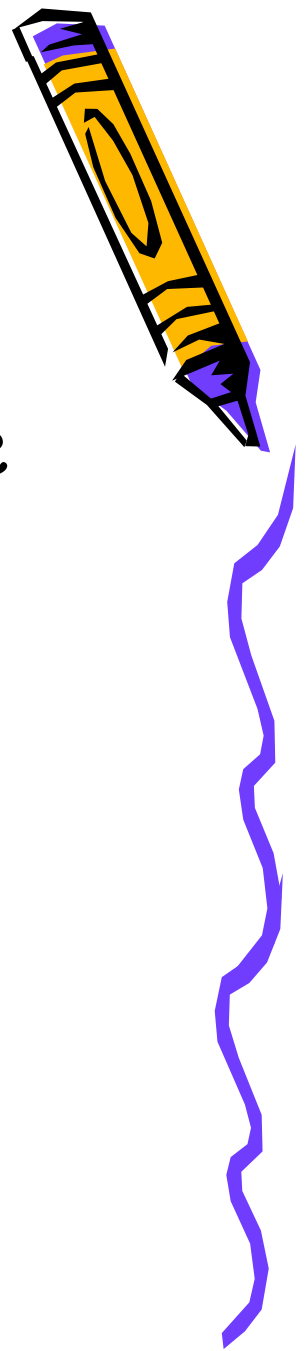

Nurturing Parent (NP)

- NP is that part of our personality that is caring, protecting, loving, and showing sympathy about other people.

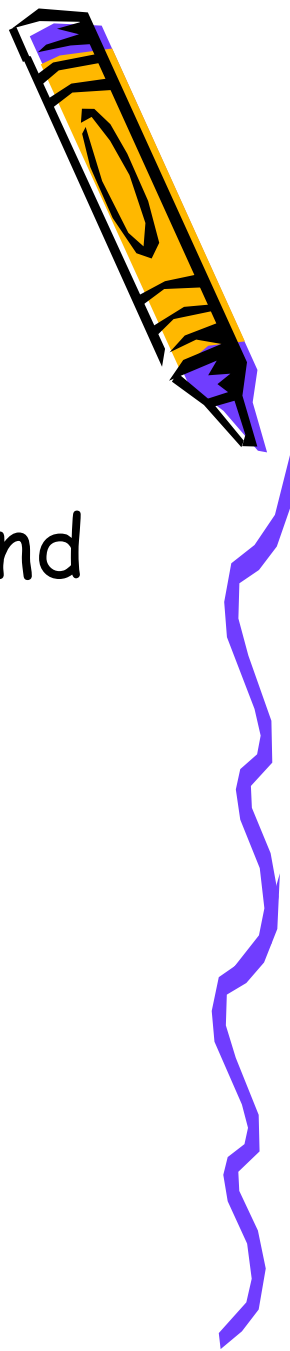

Critical Parent (CP)

- CP is that part of our personality, which tends to use do's and don'ts, sets limits and makes judgments of others.



Adult (A)

- The Adult (A) is that part of us that reflects "*life as it is thought*". It represents the developed ability to process information on the basis of past experience i.e., skills and knowledge.





- The Adult does not mean mature rather it is a logical, reasonable, rational, analytical and unemotional part of our personality.



Child (C)

- The Child is the part of us that reflects "*life as it is felt*". It represents stored pattern of behavior based on feelings experienced within ourselves early in life. It is evidenced in behavior which is emotionally expressive such as anger, fear, panic, and loving or in carefree playfulness, curiosity and creativity.



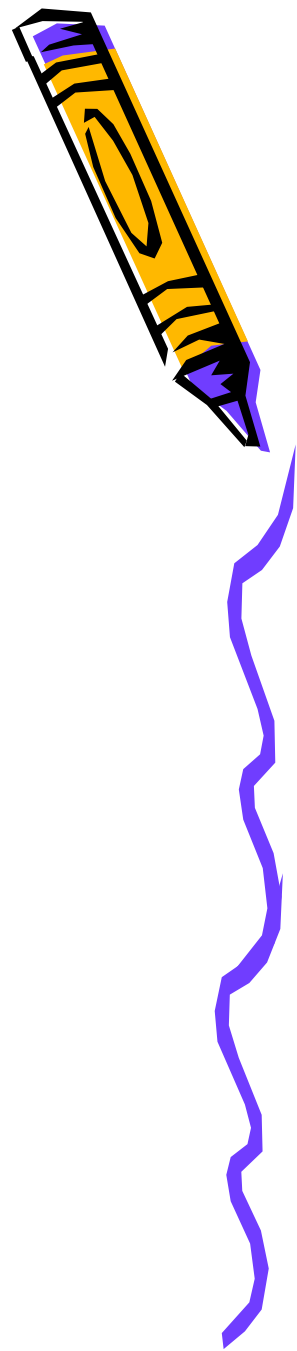

- Within the Child ego state, there are:
 1. Natural Child (NC)
 2. Adapted Child (AC)
 3. Little Professor (LP)



Natural Child

- The Natural Child (NC), is the source of our spontaneity, energy, and curiosity i.e., it is evidenced in behavior which is emotionally expressive such as anger, fear, panic, and loving or in carefree playfulness, and curiosity .

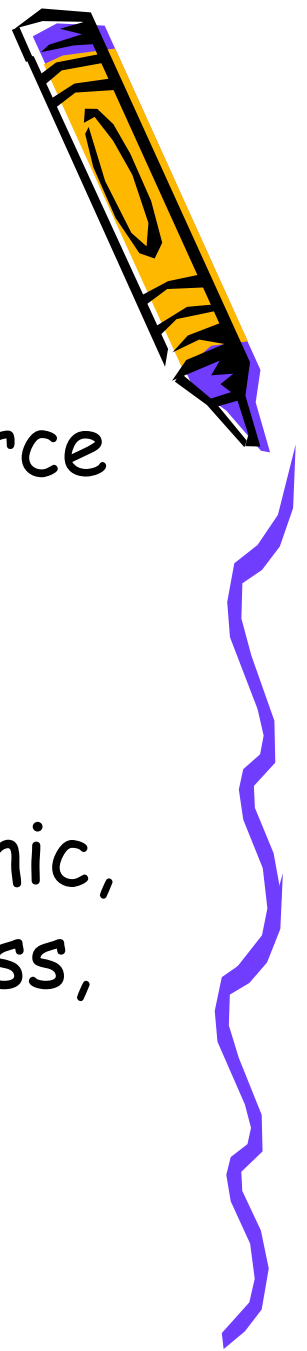

Adapted Child

- The Adapted Child (AC) is submissive rather than spontaneous i.e., complying with parents wants.

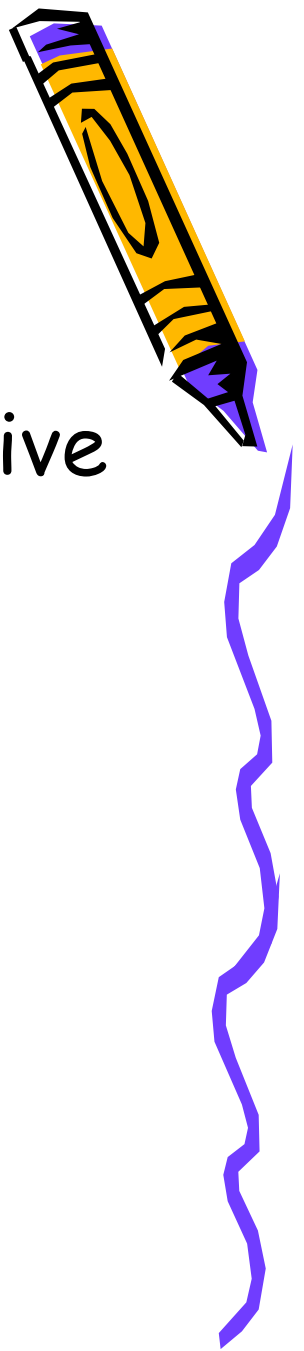

Little Professor

- The Little Professor (LP) is the intuitive, manipulative, creative and clever part of our personality.

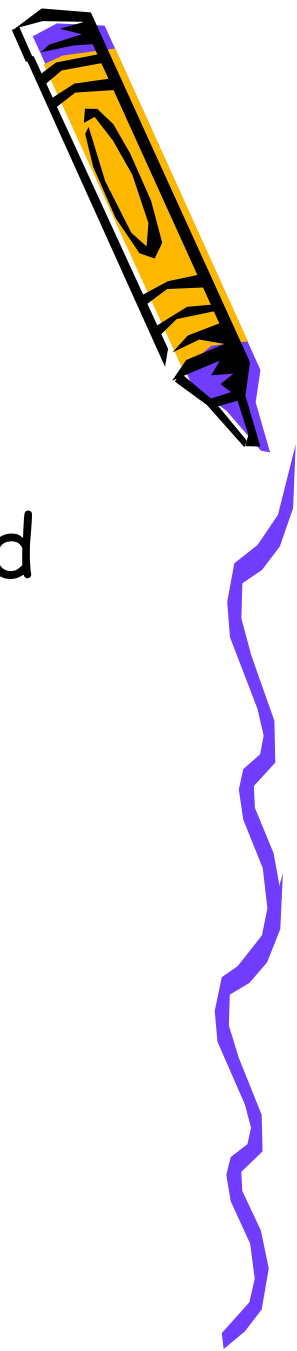

Which combination ?

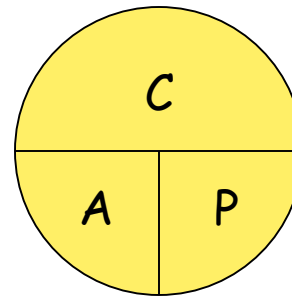
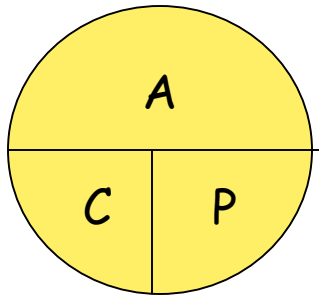
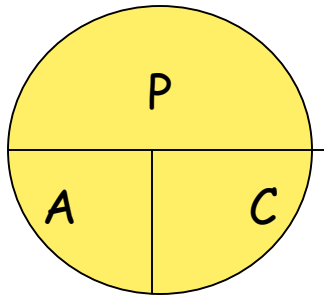

Value assumptions/life positions

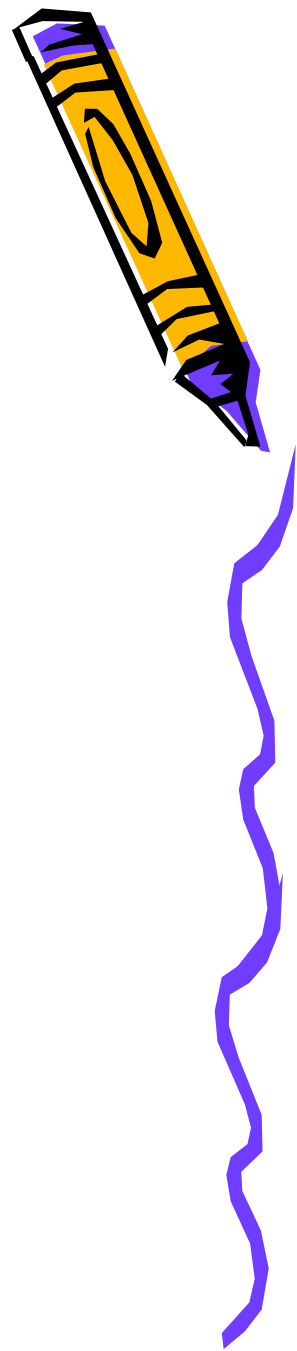

- I'm ok, You're not ok.
- I'm not ok, You're ok.
- I'm not ok, You're also not ok.
- **I'm ok, You're also ok.**



There are nine possible
transaction between two
individual

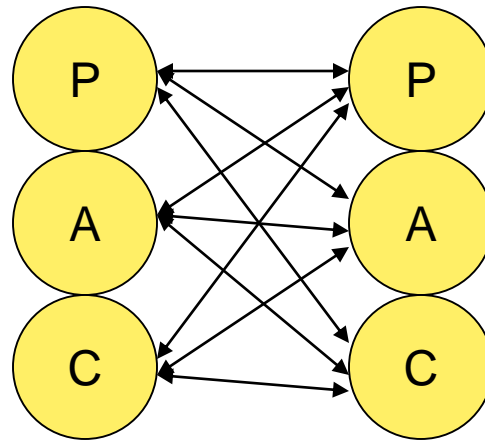

1. Complementary Transaction

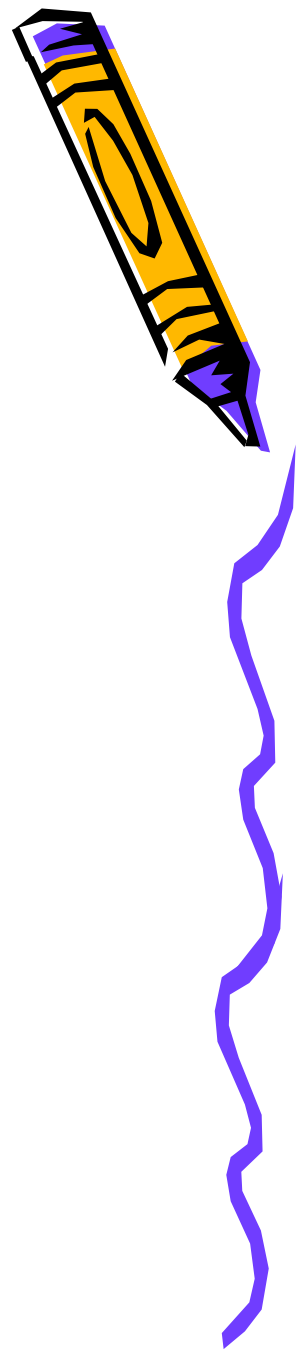
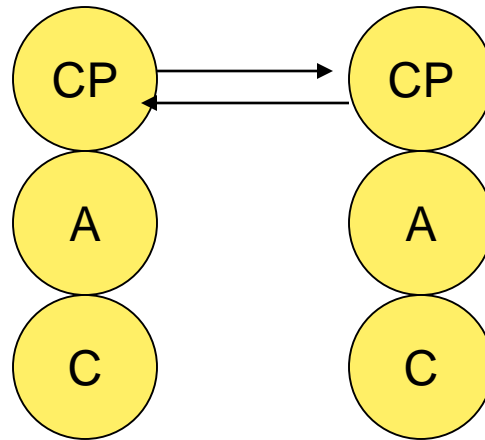

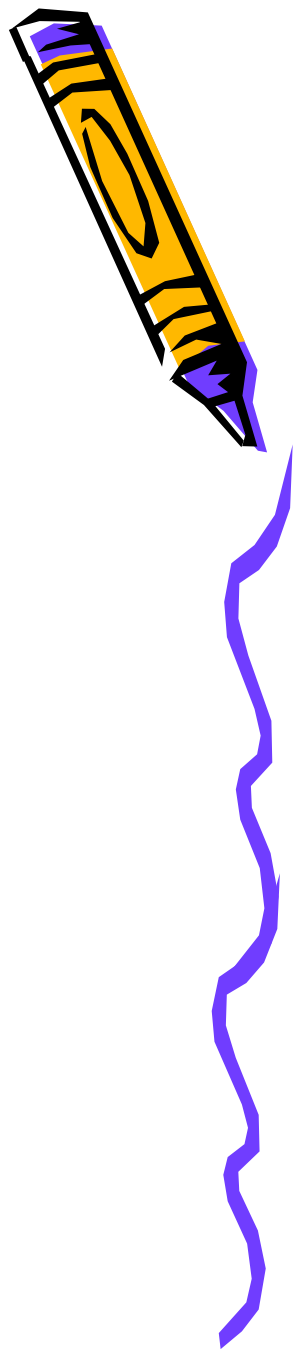
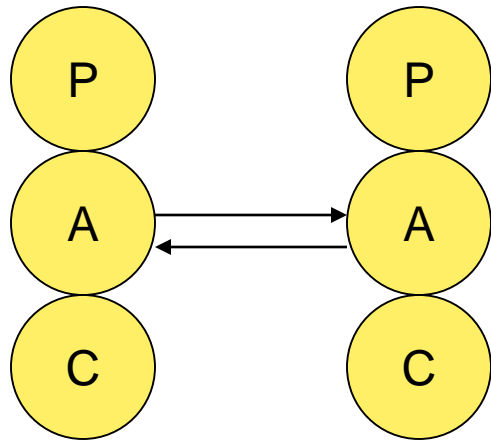

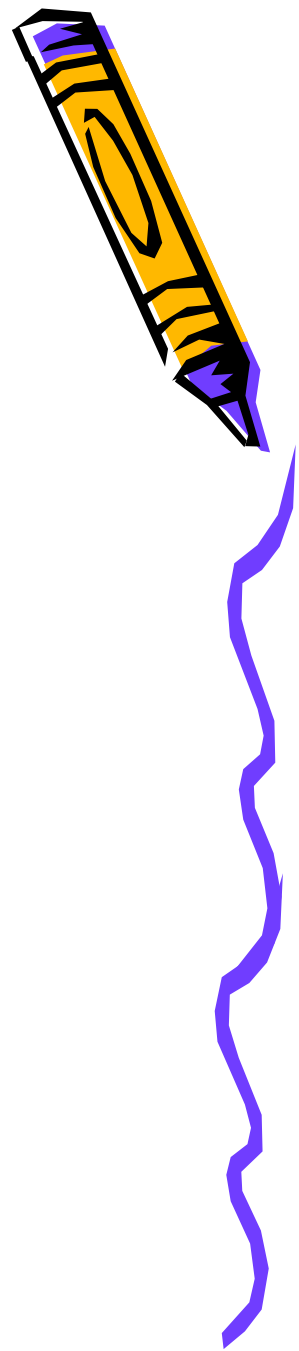
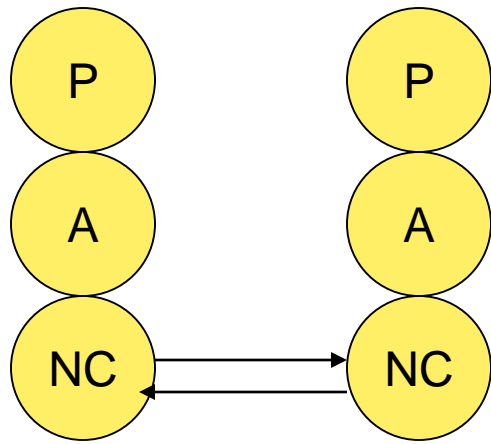

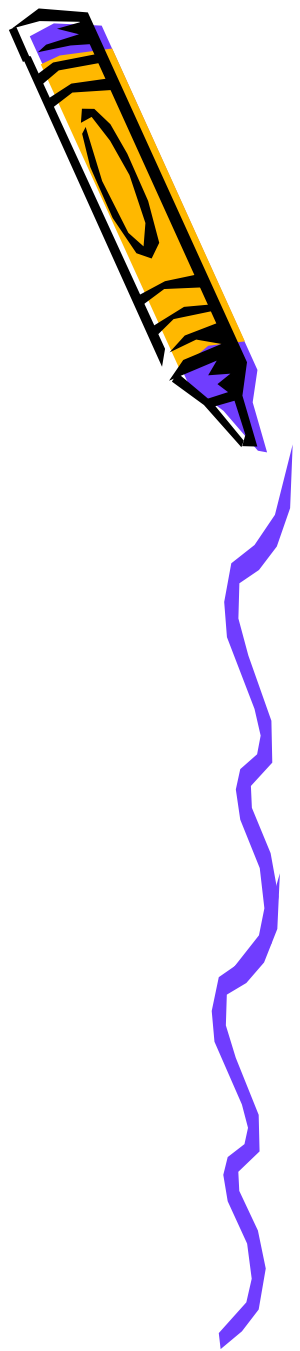
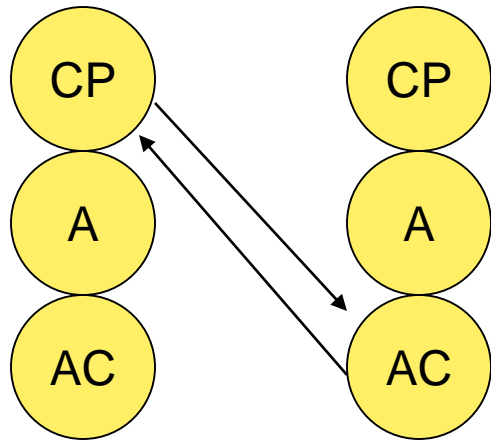

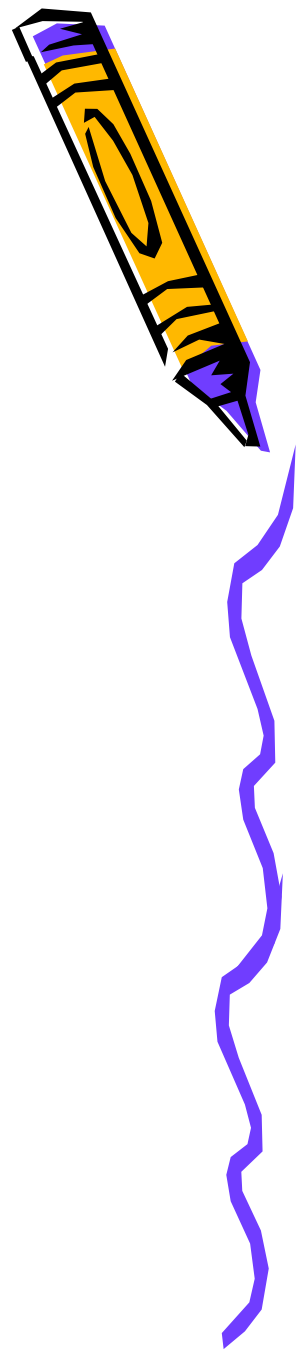

2. Crossed Transaction



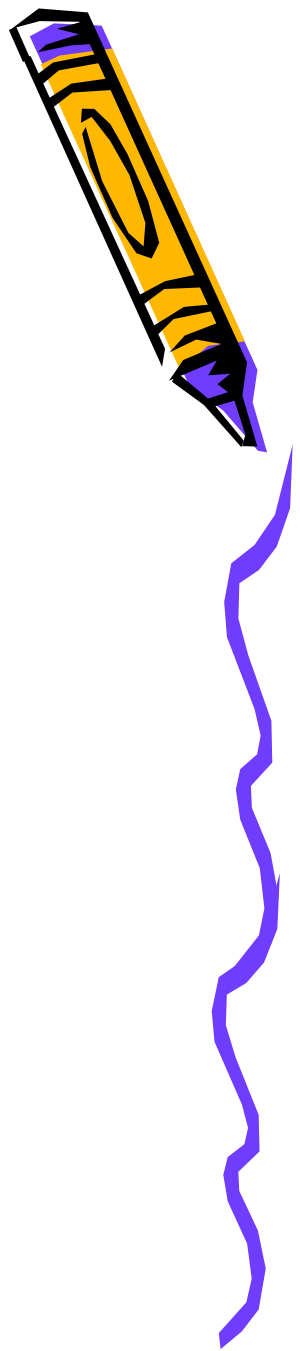
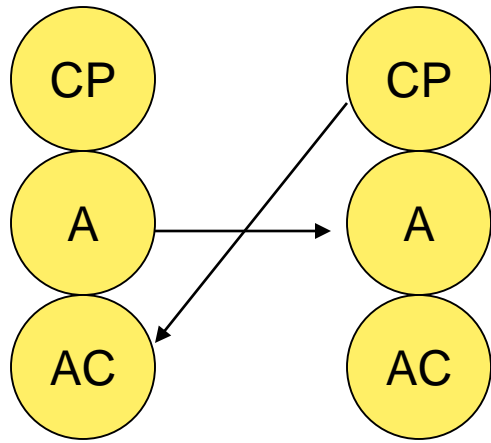

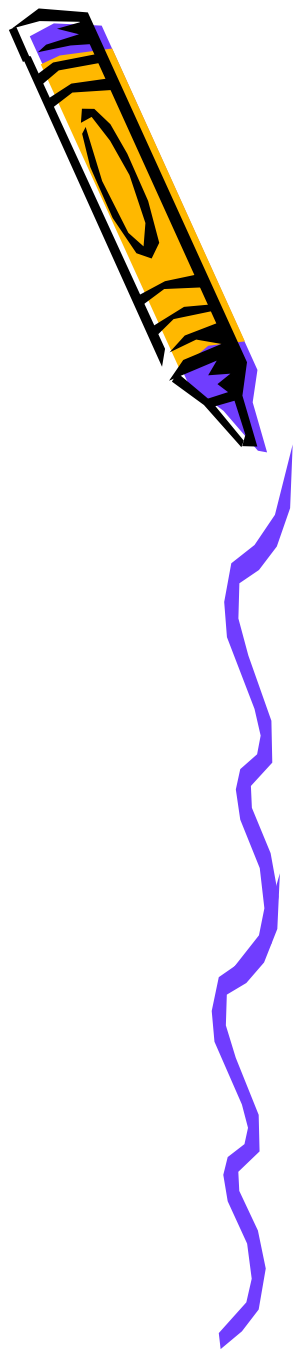
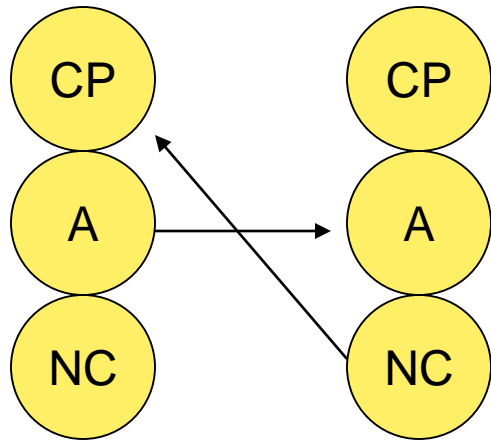

3. Ulterior Transaction

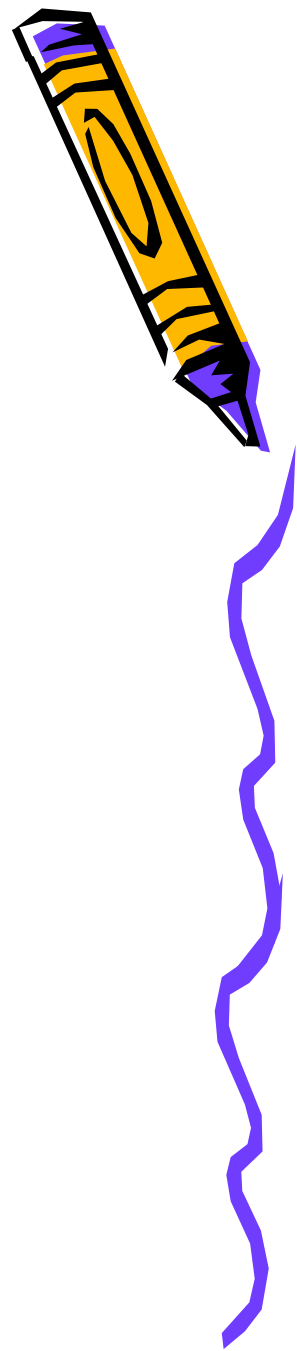

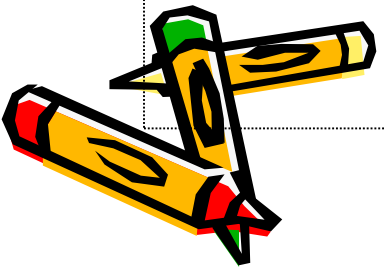
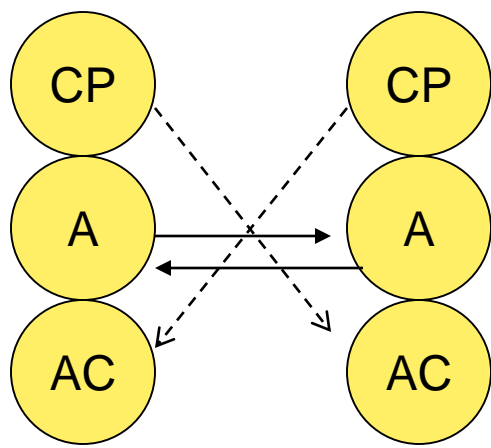
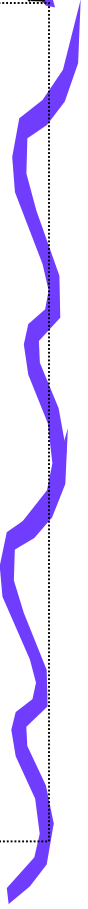

Thanks and Good day

Binod Kumar Bista/NASC/ 9851156111
binod.bista@nasc.org.np/binodb1@live.com

